

CAX0200.Bx0

AXIS INPUT CAN BUS MODULE

RT121042rev00 del 10/03/2022

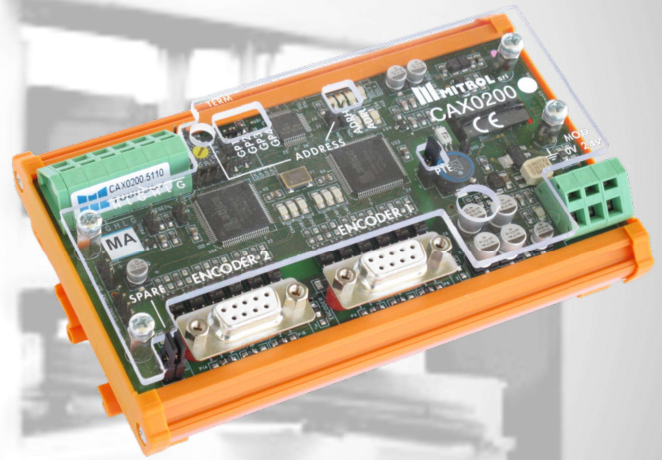

CE

CANopen

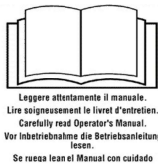

Leggere attentamente il manuale.
Lire soigneusement le livret d'entretien.
Carefully read Operator's Manual.
Vor Inbetriebnahme die Betriebsanleitung
lesen.
Se nunca lean el Manual con cuidado

Before using, read these user's manuals of this module to ensure correct usage through understanding. After reading, store them in a safe place for future reference. The manufacturer assumes no responsibility for any damage caused by mishandling that is beyond normal usage defined in this document.

1. Description

The CAX0200 it's a module with 2 input encoders type line driver 5V, designed for industrial application.

2. Technical carateristics

Dimension (H x L x P)	88 x 127 x 55mm
Weight	160g
Mounting	standard DIN rail
Immunity zone (IEC 6100-6-2)	Zone A
Power supply module (V MOD)	18..36Vdc
Power consupion (V MOD)	390mA a 24Vdc
CanBus line	125KB / 250KB / 500KB / 1MB
Marking	CE (EN61131-2)
Operative temperature	0..55°C
Storage temperature	-20..85°C
Warehousing humidity	Max. 95% non-condensing
Protection grade	IP20

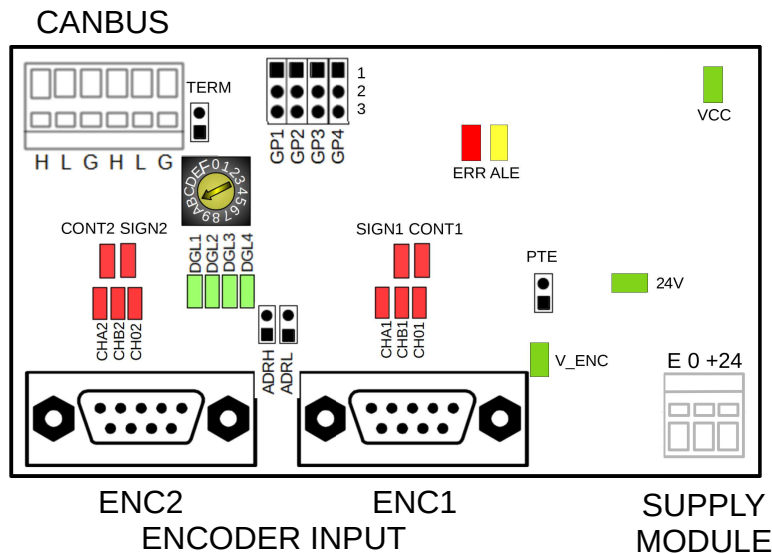

3. Module addressing, baud rate and CanBus termination

Setting switches and rotary switch are on the top of the module. They allow to set module address, CanBus rate and to terminate the line.

Jumper ADRL, ADRH and rotary switch are used to set the address; jumper GP1 and GP2 are used to set baud rate.

The default configuration is the factory setting.

ADDRESS CONFIGURATION

		commutatore rotativo															
ADRH	ADRL	0	1	2	3	4	5	6	7	8	9	A	B	C	D	E	F
open	open	-	-	2	3	4	5	6	7	8	9	10	11	12	13	14	15
open	close	16	17	18	19	20	21	22	23	24	25	26	27	28	29	30	31
close	open	32	33	34	35	36	37	38	39	40	41	42	43	44	45	46	47
close	close	48	49	50	51	52	53	54	55	56	57	58	59	60	61	62	63

DEFAULT : 2

BAUD-RATE CANBUS

Baud-rate CanBus			
GP1	GP2	speed	Max lenght cable(*1)
1-2	2-3	1 Mbps	40m
2-3	2-3	500 Kbps	80m
2-3	1-2	250 Kbps	160m
1-2	1-2	125 Kbps	320m

DEFAULT : 500 Kbps

ALARMS SETTINGS

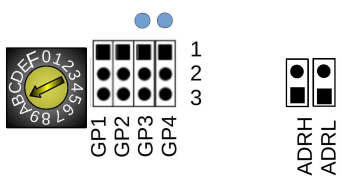

ENCODER ENC1 ALARMS		
GP3	2-3	Alarms encoder 1 enabled
	1-2	Alarms encoder 1 disabled

ENCODER ENC2 ALARMS		
GP4	2-3	Alarms encoder 2 enabled
	1-2	Alarms encoder 2 disabled

DEFAULT : GP3 – GP4 = 2-3

5V ENCODER SUPPLY

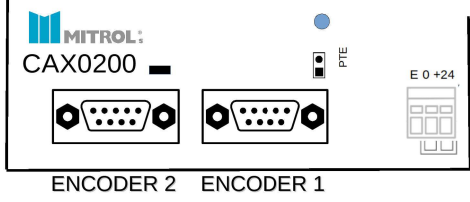

ENCODER SUPPLY		
PTE	OPEN	Encoder supply 5,380V +/- 2,5%
	CLOSE	Encoder supply 5,050V +/- 2,5%





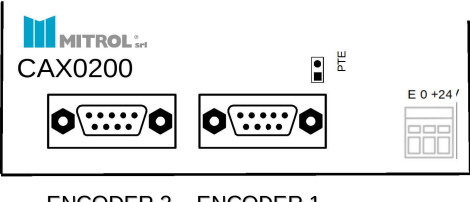

Max current 400mA



DEFAULT : PTE = CLOSE



ENCODER CONNECTOR







ENCODER CONNECTOR		
PIN	SIGNAL	DESCRIPTION
1	+5V ext	+V encoder supply
2	CH0+	CH0 positive
3	CHB+	CHB positive
4	CHA+	CHA positive
5	---	Not used
6	0V ext	-V encoder supply
7	CH0-	CH0 negative
8	CHB-	CHB negative
9	CHA-	CHA negative

Module diagnostic led		
LED VCC	 LED ON	Main cpu supply available
	 LED OFF	Main cpu supply not present
LED ALE	 LED BLK	Cpu ok
	 LED OFF	Cpu not ok
LED ERR	 LED BLK	Cpu alarm
	 LED OFF	Cpu ok

Led 5V encoder supply		
LED V_ENC	 LED BLK	5 volt available
	 LED OFF	5 volt not presente

Encoder diagnostic		
LED ENCODER	 LED CHAx BLK	Fase A active
	 LED CHBx BLK	Fase B active
	 LED CH0x BLK	Zero active

Encoder alarms		
 LED CONTx ON	Encoder ENCx alarm counting	
 LED SIGNx ON	Encoder ENCx alarm signal	

Led 24V module supply		
LED 24V	 LED ON	24 volt available
	 LED OFF	24 volt not presente

4. CanBus connection

Use shielded CanBus cable with characteristic impedance of 120 Ohm for the connection of the CanBus line. According to the CanBus specification, the connection must be made with three wires (CANH, CANL and GND_CAN). Connect the cable shield to ground with a metal clip.

Close the TERM jumper only if the module is the last in the line. (default TERM: OPEN)

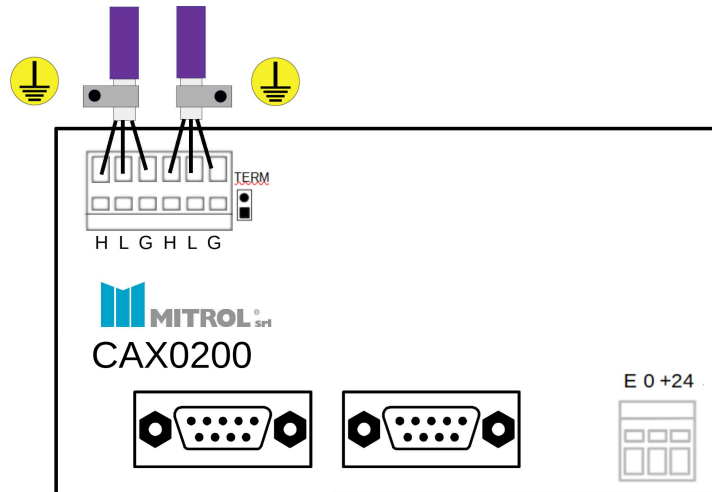

5. Module power supply connection

The terminal E is connected to the metal shell of the ENC1 and ENC2 connector; must be connected to earth!. Connect 0V of the power supply to the ground.

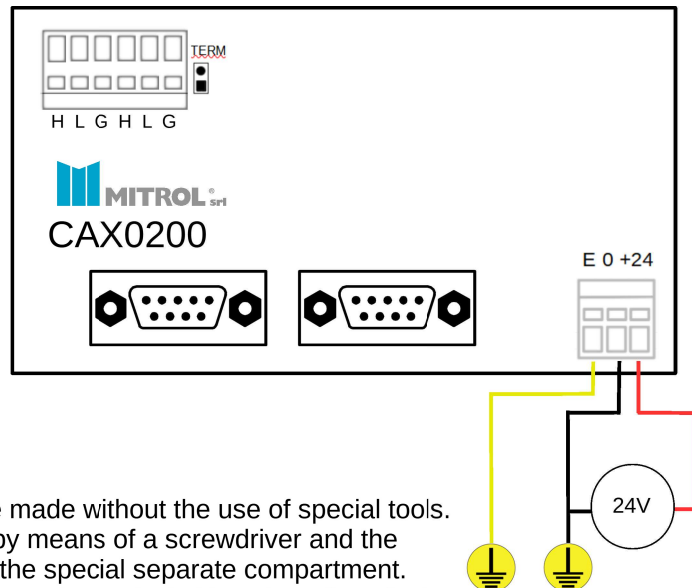

6. Instructions for using spring clamp

The spring connection allows connections to be made without the use of special tools. The actuating holes of the springs are opened by means of a screwdriver and the conductors are inserted into the cages through the special separate compartment. By removing the tool, the spring presses on the conductor (suitably stripped) prefacing the electrical connection.

Wire prescription:

- Stranded or solid with section from 0,2 a 2,5mmq (24-12 AWG);
- Stripped lenght 7mm;
- Flexible cable section with cable lug and plastic collar 0.25 to 1.5mmq.